

10.0 Genset Mounting Instructions

10.1 GENERAL MOUNTING INSTRUCTIONS

HR series generators are specifically designed for underslung mounting on railcars. The unit is designed to be supported exclusively from the (2) endplates **Item #1**. These are the **only** approved mounting surfaces; mounting of the unit from any other surface may result in catastrophic failure of the unit enclosure and will void manufacturers warranty and relieves Stadco of all responsibilities with regard to the units frame integrity and strength.

It is the responsibility of the installer to provide mounting members and necessary hardware to mount the generator unit to the railcar. Be sure to provide members with ample strength to withstand and maintain structural integrity under the impact of coupling railcars and stresses of railroad travel.

Mounting load should be evenly distributed across the entire width of the unit endplate. Do not concentrate mounting load & stresses to a small area, as this may cause structural failure of the unit endplate. Support members are to be bolted to the generator unit endplates using only high quality grade 8 hardened bolts. A series of (12) holes for 1/2" Dia. bolts are provided on each endplate.

When mounting the generator unit, be certain to mount it in a level attitude both front to back and end to end.

CAUTION: Always disconnect the battery cables before attempting to weld on the unit, otherwise damage to the battery charging alternator or other electrical components may result. General Warranty notes apply. Refer to section 14.1.

10.2 MOUNTING USING OPTIONAL SERVICE TRACK KIT #1508

Service track kit #1508 is designed to aid in periodic maintenance and service by allowing you to roll the unit out from under the railcar where it can easily be accessed from all sides. The following installation instructions will refer to **Drawings 12230-1, 12230-2, 12230-3 & 1508**.

A few items to consider before beginning installation:

- What clearances are needed for rolling genset unit in and out?

- Connection & disconnection of engine exhaust system.
- Extra length of load cables & control system cords to allow for roll out of genset unit or connection/disconnection plugs.
- Extra length of fuel hose or use of a quick disconnect coupling. Be sure to install either a shut-off valve or spill-proof couplings.

IMPORTANT: Depending upon available tools, you may need to drill the mounting holes in the main carrier rails before they are installed. See step D) for locating these holes.

- A) To mount the main carrier rails, **Item #5**, select the mounting dimension "**A**", according to GENSET MODEL. It is the installers responsibility to provide support members to attach the main carrier rails to the railcar frame structure. Support members should be attached to surfaces labeled "**Z**", of the main carrier rails. Other surfaces must remain clear to provide unobstructed roll-out of the genset unit. Be sure to provide members with ample strength to withstand and maintain structural integrity under the impact of coupling railcars and stresses of railroad travel.

IMPORTANT: Be sure to leave clearance at battery box to allow genset to roll in and out. Battery box protrudes past main carrier rail. Do not block the hot air discharge or the cool air intake openings. You can find these locations on the unit sales drawings.

Do not concentrate the mounting stresses of the support members to a small area of the main carrier rails **Item #5**, as this may cause structural failure. If the main carrier rails need to be shortened they may be cut to desired length. Position the main carrier rails **Item #5** with the roller guides facing each other. Make certain the rails are parallel with each other and level in all directions. This is important to prevent stressing of mounting members & the genset frame when bolting into position. This will also insure equal weight distribution onto rollers when rolling genset in & out.

10.0 Genset Mounting Instructions

10.2 cont'd

- B) The next step is to install & assemble the roller mounting brackets **Items #8 & #9**. Start by attaching (1) **Item #8** mounting bracket to genset endplate at right front corner. Assemble using (6) each **Item #'s 19, 20 & 21**. Securely tighten. Repeat for remaining **Item #8** at left rear corner and (2) **Item #9** at right rear and left front corners.
- C) Next step is to install rollers as shown on drawing no. 1508. Place roller **Item #11** onto spindle **Item #10**. Place (1) 3/4" SAE flat washer **Item #12** onto 3/4"-10 x 3.5" lg. grade 8 bolt **Item #13**. Insert bolt w/ washer through spindle & roller assembly, through mounting bracket **Item #8** and through genset endplate. Place a second 3/4" SAE flat washer **Item #12** onto bolt **Item #13** and tighten securely with a 3/4"-10 conical locknut **Item #14**. **Repeat step C** for the remaining three rollers.
- D) Before placing genset onto main carrier rails **Item #5** you must first locate the mounting holes for mounting bolts **Item #15**. Determine the desired genset location, drill (4) 9/16" diameter holes through main carrier rails.

The genset unit is ready to be placed onto the main carrier rails when the following steps have been completed:

1. The main carrier rails have been securely mounted to the railcar.
2. The mounting holes have been drilled.
3. The roller mounting brackets have been assembled and fastened to the genset endplates.

IMPORTANT: Be sure jacking screws **Item #18** are not protruding through support pads a greater distance than the thickness of the mounting spacers.

- E) Locate (4) mounting pad spacers **Item #16**. Spacers must be placed under mounting bracket support pads **Items #8, #9**, before fastening genset to main carrier rails. Secure the genset with (4) 1/2"x 6.00 lg. grade 8 hex head bolts **Item #15** & 1/2" grade 8 nylon locknuts **Item #17**. Roller wheels **Item #11** should not be making contact with main carrier rails when the genset is in transport (operating) position.

NOTE: Do not store extension rails, support legs, and their associated hardware inside the genset enclosure.

The following actions will automatically void all

Stadco warranty coverage:

- a. Failure to use Stadco designated attachment points for mounting the genset unit.
- b. Storing service track extensions, support jacks or any other unapproved or loose equipment inside the genset enclosure.
- c. Installation of any equipment, not approved by Stadco in writing, that would destroy the integrity, performance or service life of critical internal systems of the generator unit.
- d. Unapproved modifications to the generator unit.

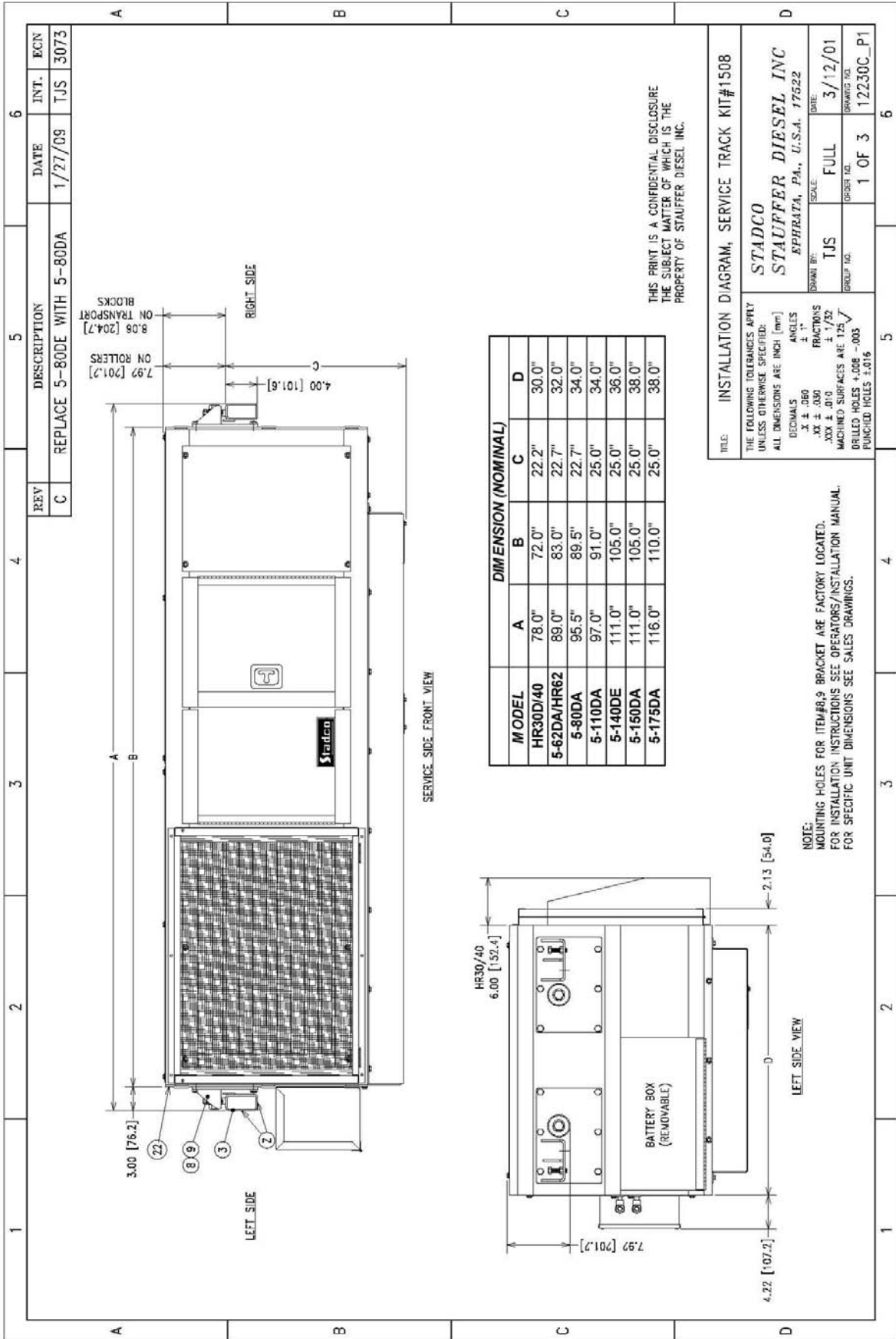

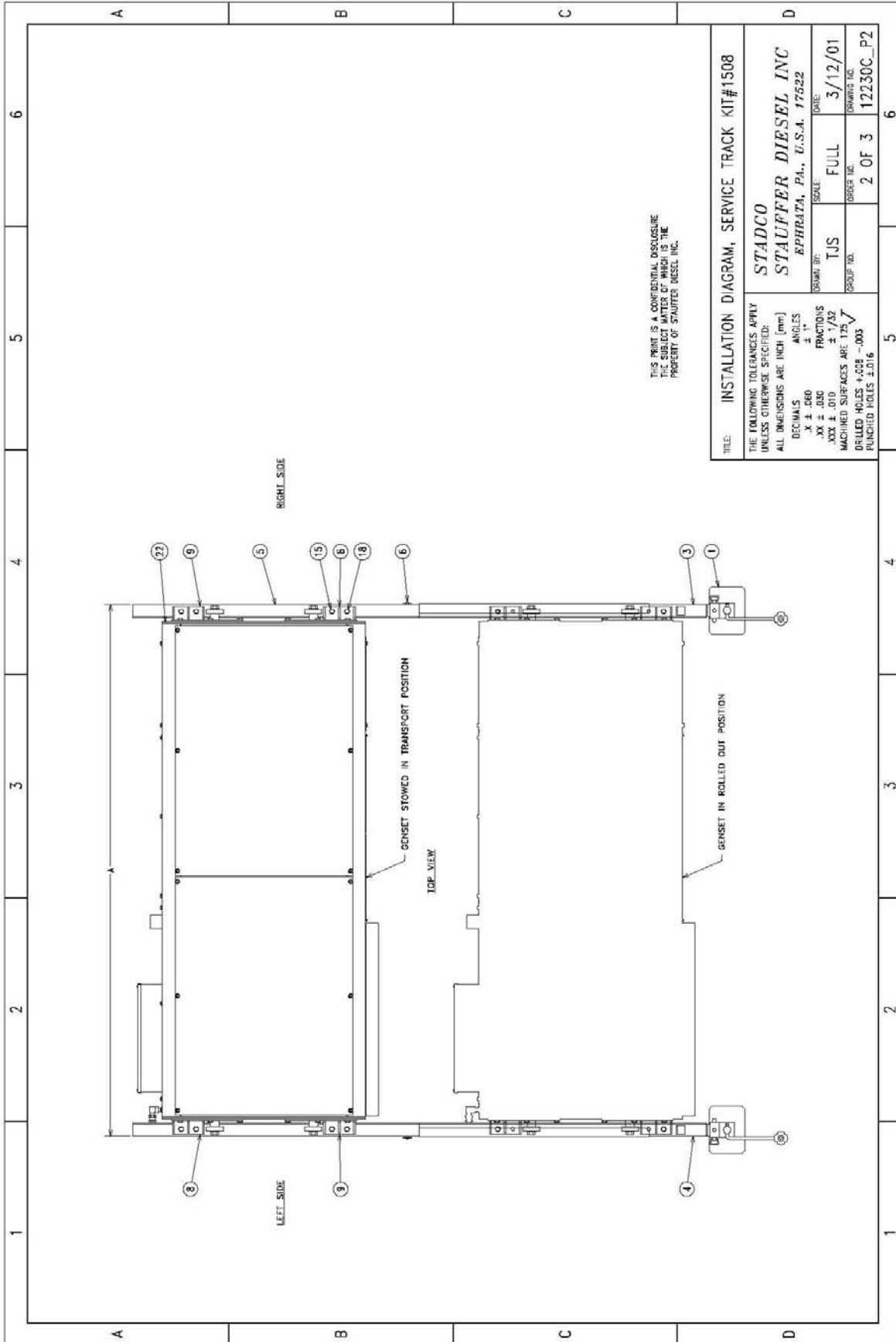

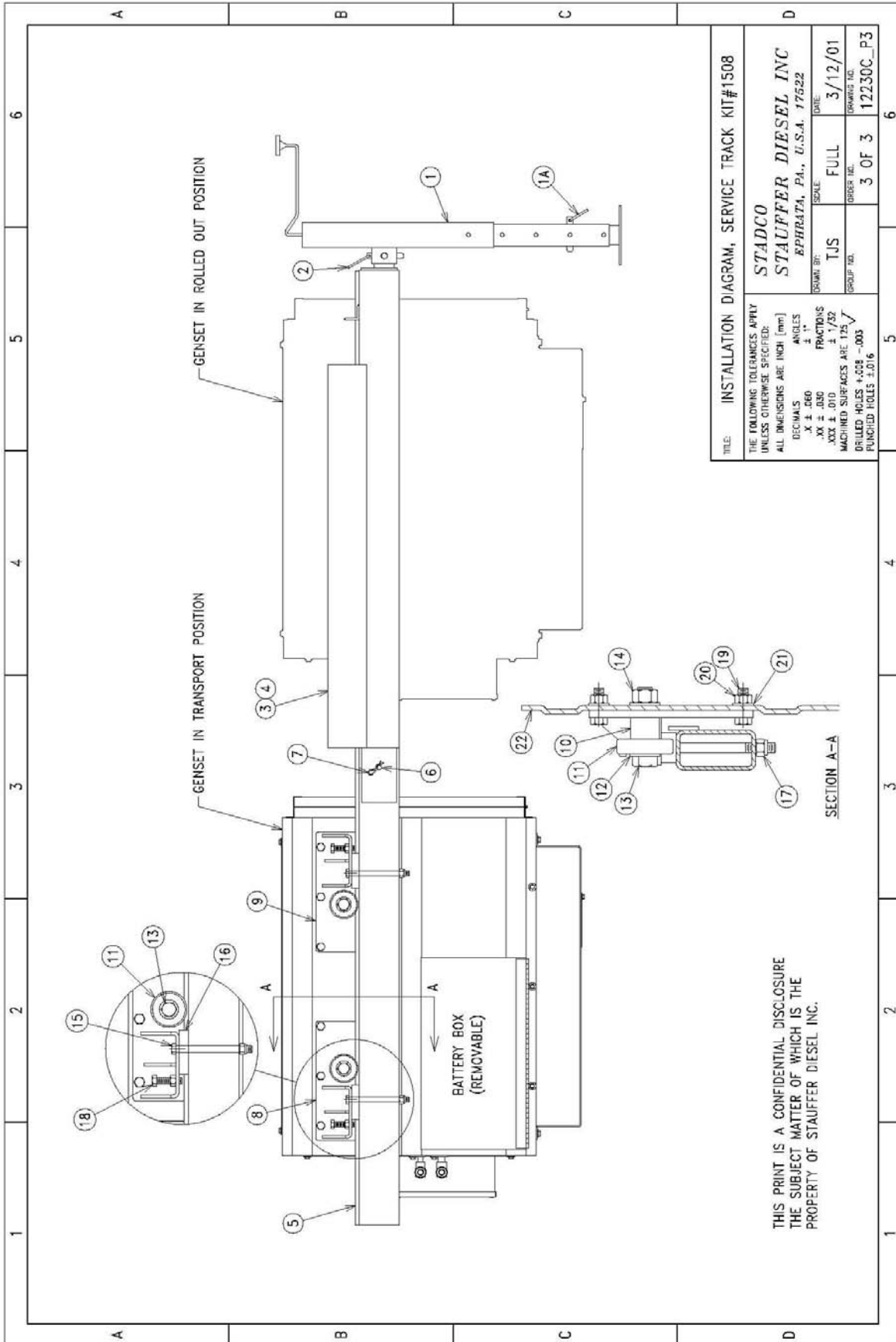

Drawing 1508

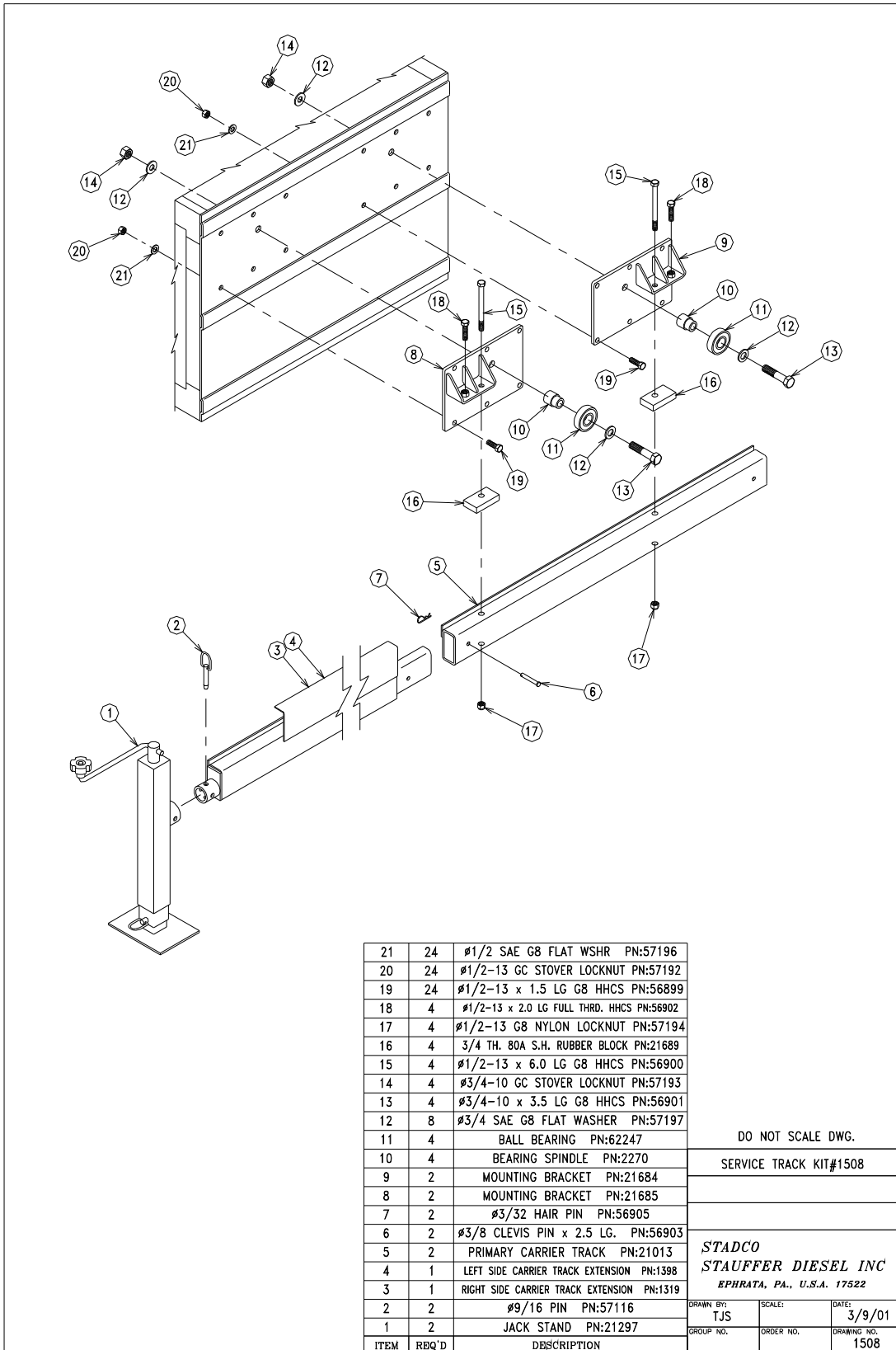

21	24	Ø1/2 SAE G8 FLAT WSHR PN:57196
20	24	Ø1/2-13 GC STOVER LOCKNUT PN:57192
19	24	Ø1/2-13 x 1.5 LG G8 HHCS PN:56899
18	4	Ø1/2-13 x 2.0 LG FULL THRD. HHCS PN:56902
17	4	Ø1/2-13 G8 NYLON LOCKNUT PN:57194
16	4	3/4 TH. 80A S.H. RUBBER BLOCK PN:21689
15	4	Ø1/2-13 x 6.0 LG G8 HHCS PN:56900
14	4	Ø3/4-10 GC STOVER LOCKNUT PN:57193
13	4	Ø3/4-10 x 3.5 LG G8 HHCS PN:56901
12	8	Ø3/4 SAE G8 FLAT WASHER PN:57197
11	4	BALL BEARING PN:62247
10	4	BEARING SPINDLE PN:2270
9	2	MOUNTING BRACKET PN:21684
8	2	MOUNTING BRACKET PN:21685
7	2	Ø3/32 HAIR PIN PN:56905
6	2	Ø3/8 CLEVIS PIN x 2.5 LG. PN:56903
5	2	PRIMARY CARRIER TRACK PN:21013
4	1	LEFT SIDE CARRIER TRACK EXTENSION PN:1398
3	1	RIGHT SIDE CARRIER TRACK EXTENSION PN:1319
2	2	Ø9/16 PIN PN:57116
1	2	JACK STAND PN:21297
ITEM	REQ'D	DESCRIPTION

DO NOT SCALE DWG.

SERVICE TRACK KIT#1508

STADCO
STAUFFER DIESEL INC
EPHRATA, PA., U.S.A. 17522

DRAWN BY:	SCALE:	DATE:
TJS		3/9/01
GROUP NO.	ORDER NO.	DRAWING NO.
		1508

10.0 Genset Mounting Instructions

10.3 MOUNTING USING OPTIONAL ISOLATION MOUNTING KIT #1498.

The intent of the Isolation mounting kit is to reduce vibration transmitted by the engine through the frame to the railcar structure. This is accomplished by installing a set of (4) rubber mounts at the corners of the generator enclosure. Since the enclosure is mounted on rubber it will be able to move with vibration as well as when coupling the railcars together. For this reason all attaching parts such as fuel lines, exhaust system, wiring etc. **can not** be rigidly attached when making your connections. Make sure these connections are installed with sections of flexible material as required. The following installation instructions will refer to **Figure 10.3.1 & 10.3.2**.

Before beginning installation read **Section 10.1 General Mounting Instructions**.

Begin by determining distance "A" on chart **Figure 10.3.1**. After distance "A" is determined, you will need to decide what support members are going to be used to carry the generator set. The generator set is carried by attaching to (4) brackets **Item #2, Figure 10.3.1**. Be sure to provide support members with ample strength to withstand and maintain structural integrity under the impact of coupling railcars and stresses of railroad travel. If welding to the railcar structure, have a certified welder perform the installation. If you are fastening the support members by means of bolting, use Grade 8 hardware or better. When installing, be sure the mounting surfaces of the support members are parallel and level. The holes for attaching to bracket **Item #2** can be drilled according to layout shown in **Figure 10.3.1**.

After the carrying members are securely attached to the railcar structure assembly of the mounting kit can begin.

The following instructions refer to Figure 10.3.2.

First, attach mounting brackets **Item #1** to the generator endplate. Make sure the mounting brackets are parallel with each other and with the top of the generator enclosure.

This will help ensure a level mounting when installed on the railcar. Use Grade 8 hardware (provided) **Item #7, Item #8 & Item #9**, 6 places each bracket. Tighten securely.

Note: A chart of general tightening specs for different grade hardware is shown in **Figure 10.7.2**.

Second, place isolation mounts **Item #10** onto brackets **Item #2** and secure with Grade 8 hardware (provided) **Item #7, Item #8 & Item #9**, 2 places each mount. Tighten securely.

Next, align bracket **Item #2** with 13/16" dia. hole in bracket **Item #1**. Place washer **Item #4** on 3/4-10 Grade 8 bolt **Item #3**. Insert bolt through bracket **Item #1** and rubber mount **Item #10** and secure by placing snubber washer **Item #5** and locknut **Item #6** onto bolt **Item #3**. Thread locknut onto bolt only to locking section of the nut. This will allow you to align the brackets more easily with the main carrier members.

Repeat for remaining (3) brackets.

After the brackets are assembled, the unit is ready to be mounted and fastened to the railcar structure.

Lift the genset enclosure into the designed position and attach to the railcar using Grade 8 bolts & locknuts (not provided). Each bracket **Item #2** is designed to be attached using (6) 1/2" diameter bolts. Tighten securely.

Make sure that all mounts are equally loaded when in the installed position. This will provide the best isolation from vibration and also will prevent overloading of one mount. To check equal load, keep center bolts **Item #3** loose. Lift one end of the generator enclosure until brackets **Item #1** do not make contact with rubber mount **Item #10**. Next, slowly lower down until either bracket **Item #1** contacts the rubber mount. Adjust brackets as needed to correctly align. Repeat this process for the opposite end.

When the genset is positioned and properly aligned, tighten (4) locknuts **Item #6** onto bolts **Item #3**.

Before completing, recheck all fastening hardware for tightness.

Figure 10.3.1 (Dwg 12239)

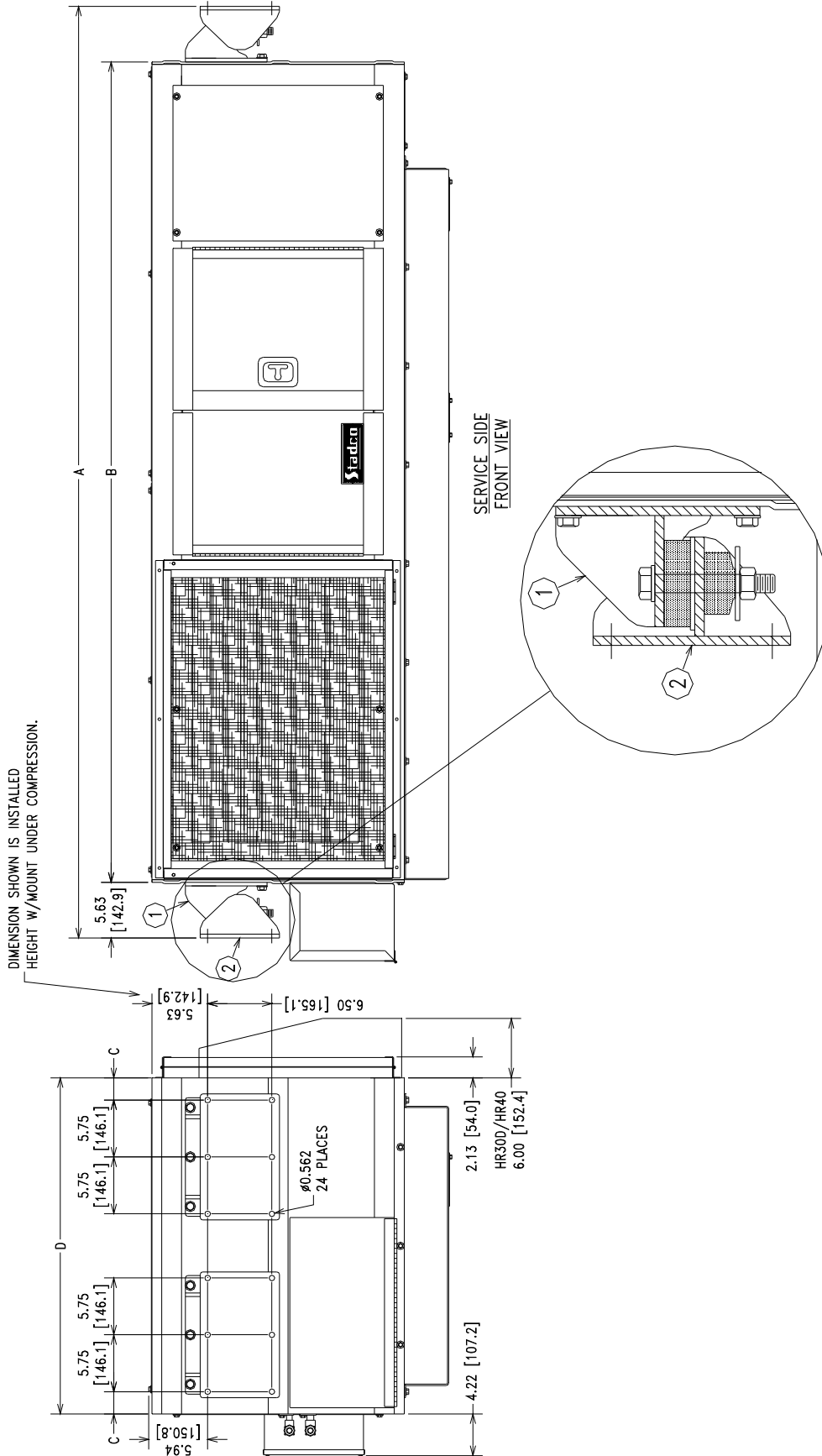
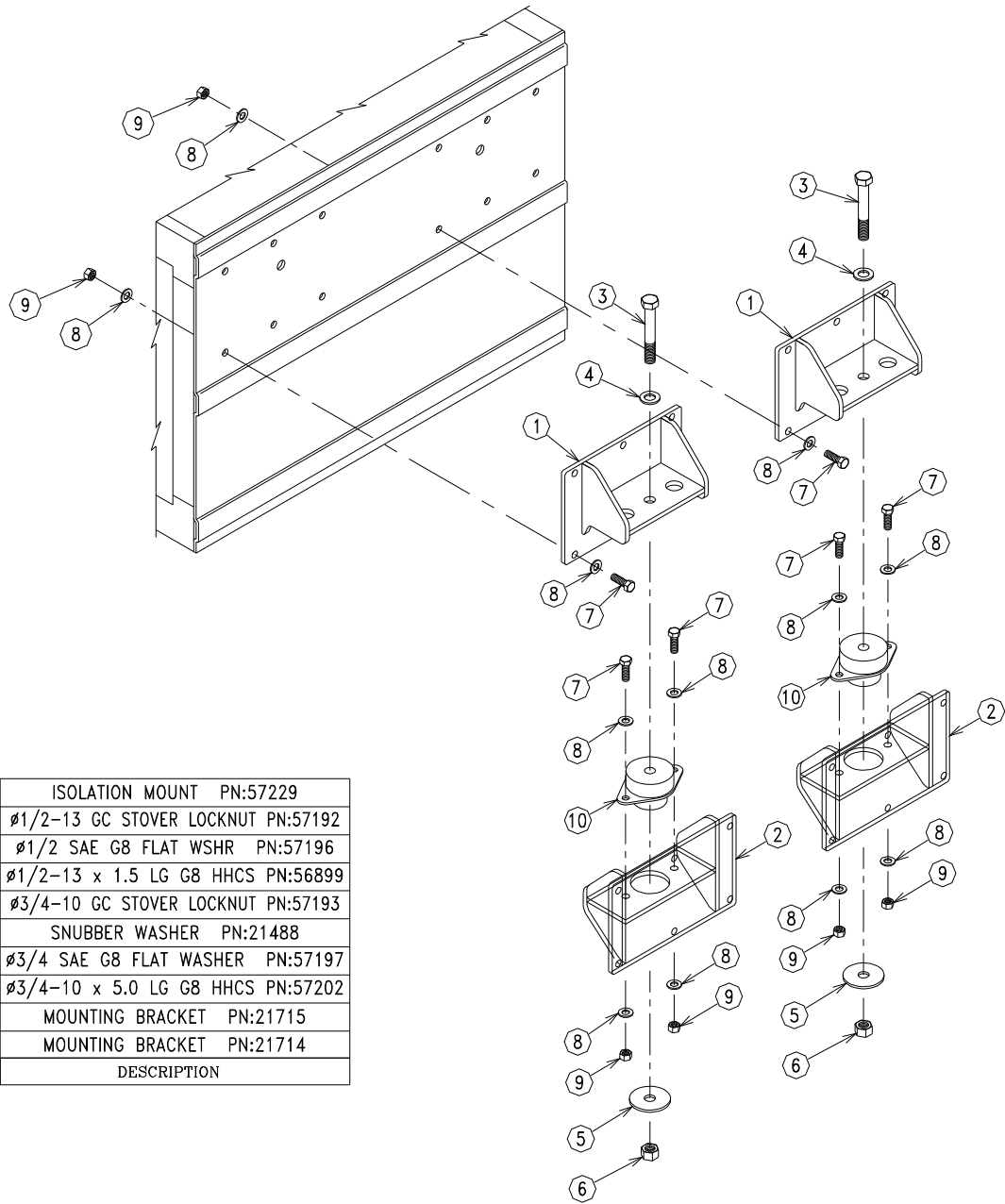

Figure 10.3.2 (Dwg 1498)



10	4	ISOLATION MOUNT PN:57229
9	32	Ø1/2-13 GC STOVER LOCKNUT PN:57192
8	64	Ø1/2 SAE G8 FLAT WSHR PN:57196
7	32	Ø1/2-13 x 1.5 LG G8 HHCS PN:56899
6	4	Ø3/4-10 GC STOVER LOCKNUT PN:57193
5	4	SNUBBER WASHER PN:21488
4	4	Ø3/4 SAE G8 FLAT WASHER PN:57197
3	4	Ø3/4-10 x 5.0 LG G8 HHCS PN:57202
2	4	MOUNTING BRACKET PN:21715
1	4	MOUNTING BRACKET PN:21714
ITEM	REQ'D	DESCRIPTION

10.4 Exhaust System

10.4 EXHAUST SYSTEM

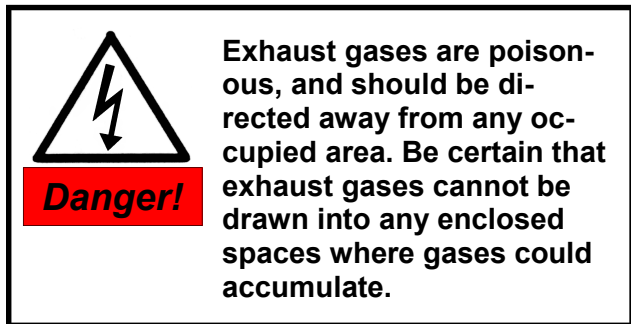

An exhaust tailpipe is supplied from the engine manifold to the outside of the unit. To complete the exhaust system an exhaust components kit has been shipped loose with the generator unit. Refer to **Figure 10.4.1**.

MUFFLER

The exhaust muffler should be mounted as far as possible away from the generator air inlet openings. The outlet end of the muffler should be pointed away from the air inlet side of the generator unit so as not to recirculate the exhaust heat. Two mounting brackets are supplied for mounting the exhaust muffler.

RAIN PROTECTION

With vertical exhaust systems the entry of rain and/or snow must be prevented by installing a rain cap, or by bending the tailpipe to provide a horizontal exhaust outlet.

PIPING

When installing piping between genset unit and muffler refer to **Figure 10.4.1** for assembly. The flexible exhaust piping may be cut to length for proper installation. It may be necessary to provide additional piping if mounting the muffler a greater distance from the generator unit. If excessively long runs are required it may be necessary to increase piping size. Consult Stadco main office for determining piping size.

EXHAUST ELBOWS

Provide sweeping bends to minimize exhaust backpressure. 90° elbows must have a radius not smaller than the pipe I.D. Do not miter cut piping to create elbows. This will greatly restrict the exhaust flow, which can cause engine overheating.

EXHAUST BACKPRESSURE

The exhaust system will produce a certain resistance to the exhaust gas flow ("exhaust backpressure") consisting of the total resistance of the system, including the pipes, pipe bends, muffler, tailpipe and/or exhaust accessories. The exhaust backpressure of a given engine installation will depend upon the size of the pipes, the number and types of bends and joints and the chosen muffler. Exhaust system design must ensure that the total system flow resistance does not exceed the maximum permissible backpressure, Refer to **Section 10.7** for exhaust backpressure limit. The exhaust system supplied by Stadco has been designed to be within these parameters.

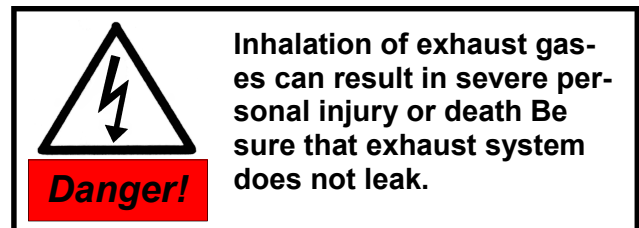
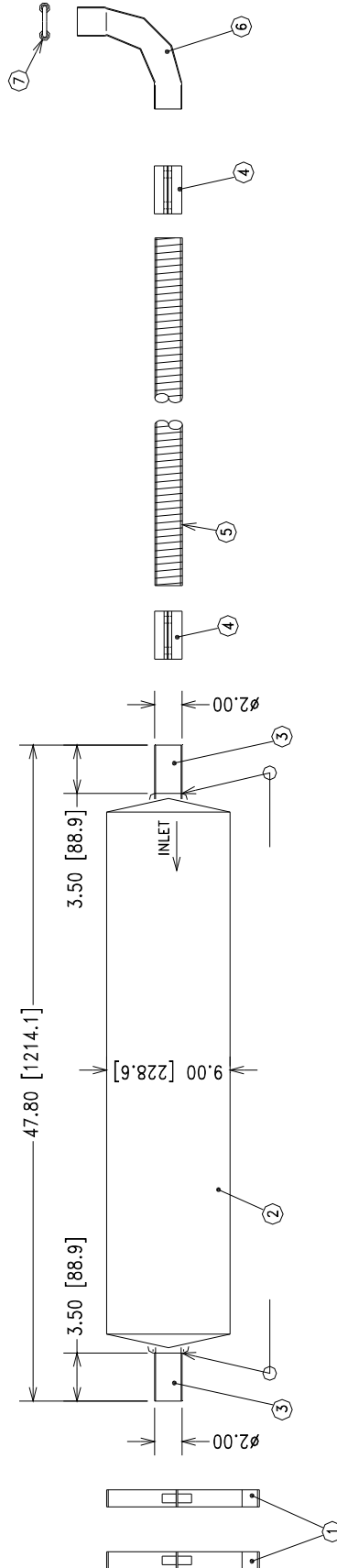
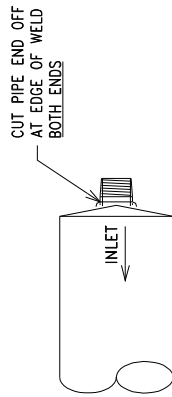

Figure 10.4.1 (Dwg 1362)

7	1	Ø2" MUFFLER CLAMP	PN:5064
6	1	Ø2" ALZD. EXH. ELBOW	PN:5465
5	1	Ø2" X 10' LG. GALV. FLEX TUBE	56626
4	2	Ø2" SEAL CLAMP	X004536 PN:57069
3	2	Ø2" X 3.5" ALZD. EXH. TUBE	PN:56368
2	1	MUFFLER 41320P	PN:57068
1	2	MTG. BANDS	PN: 56712
ITEM	REQ'D	DESCRIPTION	



10.5 FUEL SYSTEM

The fuel system supplied with this unit is equipped with a secondary fuel filter which is mounted on the diesel engine, and a primary fuel filter/water separator, which is shipped loose for remote mounting. It is imperative to have a clean supply of fuel to prevent contamination of the fuel injection system.

Refer to the Fuel System Layout, **Figure 10.5.1**, for a typical layout. Fuel supply fittings are provided, located on the exhaust outlet side of the unit, beside the distribution box. The connections supplied are 3/8" hose connection fittings. Use a minimum of 3/8" ID hose for connection between the genset and the fuel tank. In order for this system to work properly make certain that all connections are air tight. Place a clamp on all fuel hose connections to prevent air from entering the system and fuel from leaking out. Rigid lines or Push-Loc type fuel hoses may be used to make the connections. Rigid lines made of copper or scale-free steel, should be carefully cleaned before installation. Flexible hoses should be used to make connections between rigid lines and genset unit to allow for movement. All fuel lines and hoses should be adequately retained to prevent chafing. In areas where hoses may come in contact with frame members or other equipment, the hose should be covered with a protective loom and firmly clamped.

The primary fuel filter/water separator should be installed into the fuel suction line, in a vertical manner, and in an accessible area to permit periodic draining of accumulated water. This filter must be mounted outside the genset enclosure. See warranty notices.

Each unit is equipped with a mechanical engine mounted fuel transfer pump which feeds the fuel supply from the fuel tank to the fuel filter system and subsequently to the fuel injection pump.

IMPORTANT: Air cavitation causes engine starting problems by virtue of fuel starvation. To avoid this condition make sure that all joints and connections in the fuel system are 100% air tight. Install spring loaded type, fuel check valve at fuel tank if difficulty is encountered with fuel drain-back.

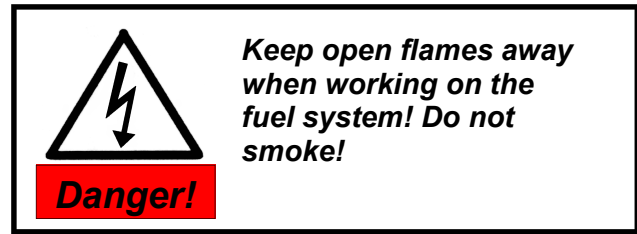

10.6 COOLING AIR SYSTEM

Deutz B/FM2011 engines are oil-cooled diesels. The genset is complete with a heat exchanger and cooling fan. It is essential that oil-cooled diesel engines be installed in such a way that a proper supply of cooling air is guaranteed under all operational conditions. The following rules must be followed:

Cooling air flow to the genset must be isolated from all extraneous heat producing equipment. Recirculated heat of any kind, regardless of source, may cause engine to overheat at full rated load, especially at or above rated ambient temperatures (80°F). When the engine is running, a vacuum is formed in front of the cooling air inlet duct of the enclosure, drawing air streams there from all directions. The key to a proper installation is to allow only fresh ambient air to enter the unit and to eliminate the possibility of hot air recirculation.

Cooling air flow enters the enclosure exclusively at the air intake duct **Figure 4.1.1** on the service side as shown on STADCO sales drawing. Do not cover the air intake duct or restrict cooling air flow to the panel. Prior written Stadco factory approval must be obtained for installation where cooling air duct will be restricted in any way. Hot air discharges downward from the front of the unit **Figure 4.1.1**. The air intake opening is protected with a cleanable filter system to prevent the passage off dirt and debris which could clog the radiator. Hot air discharge opening is protected with a rock guard/screen to protect the cooling system. Always keep these openings clean and free of obstructions.

Make sure the oil level is up to full mark before starting the engine. Some engines are equipped with a low oil level switch and will cause the engine to shut down if not properly maintained. To fill oil see Section 11.2 for instructions.

Figure 10.5.1 (Dwg 11603)

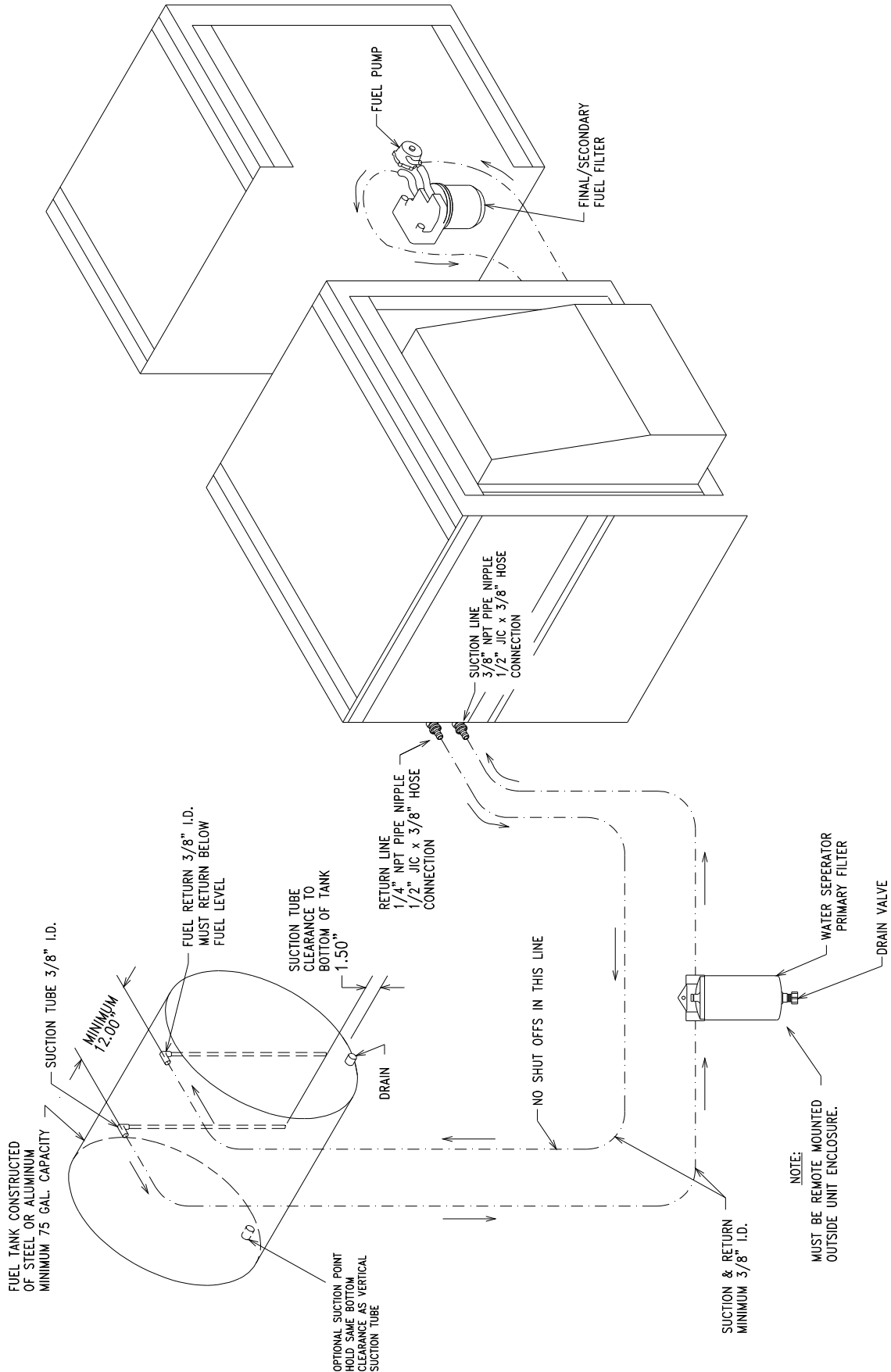

10.7 Design Features & Specifications

Item	Unit	HR30D	HR40
Engine Speed	RPM	1800	1800
Engine Model		F4M2011	BF4M2011
Recommended Battery Capacity	CCA	1100	1100
Recommended 12VDC Battery Type	BCI#	31	31
* Engine Lube oil Capacity with Filter & Oil Cooler	Quarts	14.8	14.8
Combustion Air Flow	CFM	79	130
Maximum Intake Restriction	In. H2O	26	26
Exhaust Gas Flow	CFM	214	353
Max. Exhaust Backpressure	In. H2O	30	30
12386 specifications.xls			

Figure 10.7.1

** Oil capacity listed is approximate only. Always use upper marking on dipstick as actual fill level. See section 11.2 for filling instructions.*

HARDWARE TIGHTENING TORQUE

The following chart is to be used as a general guideline for tightening specifications of standard steel bolts (Hardware dry, non-lubricated and zinc plated). The upper value of each grade is the minimum yield strength of that grade. These are not to be used for tightening specifications of bolts and other hardware on the engine or generator. See engine/generator manufacturers torque specs for fasteners.

Bolt Size	SAE GRADE 2		SAE GRADE 5		SAE GRADE 8	
	Tightening-Torque Range (lbs-ft)	Clamp Load Range (lbs)	Tightening-Torque Range (lbs-ft)	Clamp Load Range (lbs)	Tightening-Torque Range (lbs-ft)	Clamp Load Range (lbs)
¼-20	5.7 to 4.3	1813 to 1360	9.1 to 6.9	2926 to 2195	12.9 to 9.7	4134 to 3101
¼-28	6.5 to 4.9	2075 to 1556	10.5 to 7.9	3349 to 2512	14.8 to 11.1	4732 to 3549
⅜-18	11.7 to 8.8	2987 to 2240	18.8 to 14.1	4821 to 3616	26.2 to 20.0	6812 to 5109
⅜-24	12.9 to 9.7	3306 to 2480	20.8 to 15.6	5336 to 4002	29.5 to 22.1	7540 to 5655
½-16	20.7 to 15.5	4418 to 3314	33.4 to 25.1	7130 to 5348	47.2 to 35.4	10075 to 7556
½-24	23.5 to 17.6	5005 to 3754	37.9 to 28.4	8078 to 6059	53.5 to 40.1	11414 to 8561
¾-4	33.1 to 24.9	6059 to 4544	53.5 to 40.1	9780 to 7335	75.6 to 56.7	13819 to 10364
¾-20	37.0 to 27.8	6766 to 5075	59.7 to 44.8	10920 to 8190	84.4 to 63.3	15431 to 11573
1-13	50.6 to 37.9	8088 to 6066	81.6 to 61.2	13055 to 9791	115.3 to 86.5	18447 to 13835
1-20	57.0 to 42.7	9114 to 5835	91.9 to 69.0	14711 to 11033	130.0 to 97.4	20787 to 15590
1¼-12	73.0 to 54.7	10374 to 7780	117.7 to 88.1	16744 to 12558	166.4 to 124.8	23660 to 17745
1¼-18	81.4 to 61.0	11571 to 8678	131.3 to 98.1	18676 to 14007	185.6 to 139.2	26390 to 19793
1½-11	100.6 to 75.5	12882 to 9662	162.4 to 121.8	20792 to 15594	229.5 to 172.1	29380 to 22035
1½-18	114 to 85.5	14592 to 10944	184 to 138	23552 to 17664	260.0 to 195.0	33280 to 24960
1¾-10	178.5 to 133.9	19038 to 14279	288 to 216	30728 to 23046	407.1 to 305.3	43420 to 35368
2-16	199 to 149.5	21261 to 15946	321.7 to 241.3	34316 to 25737	454.6 to 341.0	48490 to 45045
2-9	288 to 216	26334 to 19751	464.9 to 348.7	42504 to 31878	656.9 to 492.7	60060 to 45045
2-14	317 to 238	29013 to 19751	512.2 to 384.1	46828 to 35121	723.7 to 542.8	66170 to 49628
1-8	432 to 324	34542 to 25907	696.9 to 522.7	55752 to 41814	984.8 to 738.6	78780 to 59085
1-12	472 to 354	37791 to 28343	761.1 to 571.8	60996 to 45747	1077 to 808	86190 to 64643

Figure 10.7.2