

8 7 6 5 4 3 2 1

REVISIONS				
REV.	DESCRIPTION	DATE	INIT	ECN
A	ADD MANIFOLD MUFFLER	12/06/2012	BKH	3293
B	NEW CONTROL PANEL 1779	6/20/2013	TJS	3335

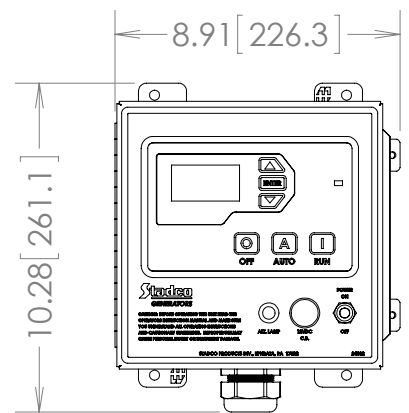

STANDARD 1779 CONTROL PANEL

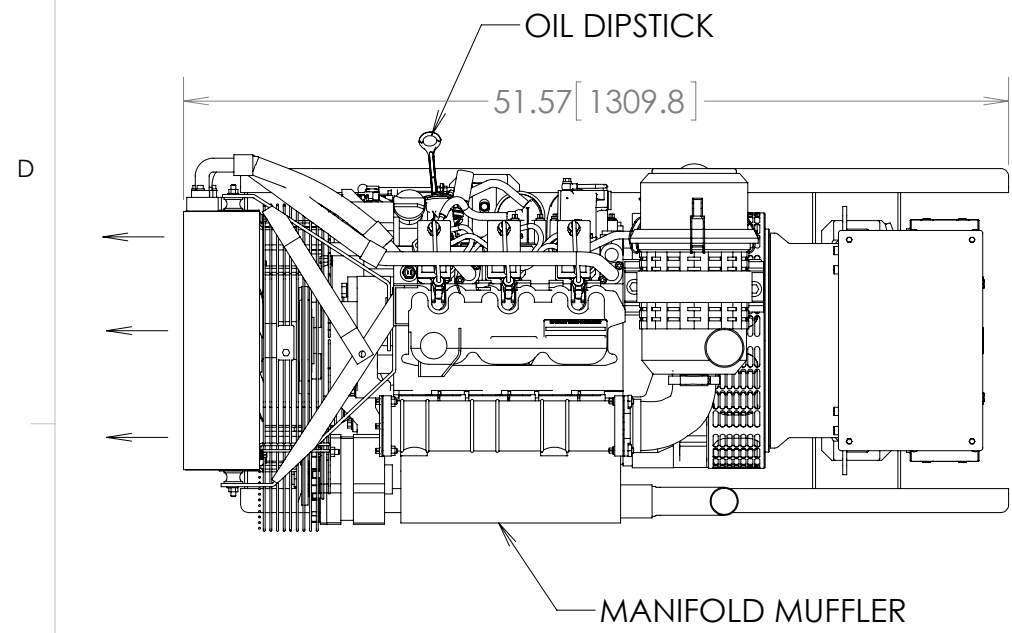
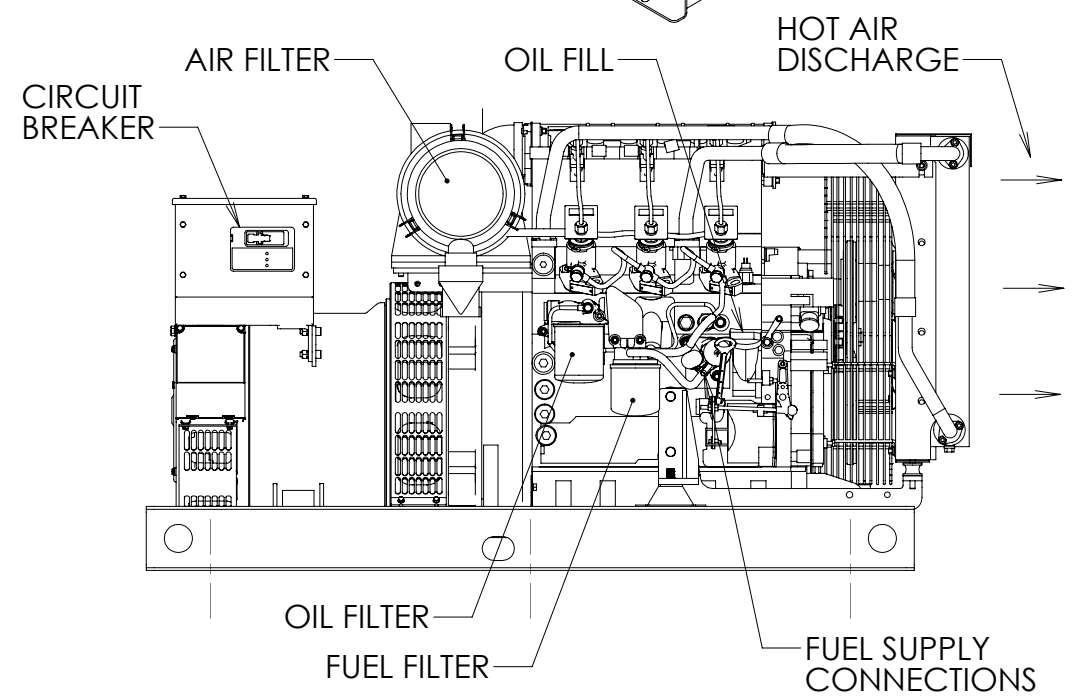
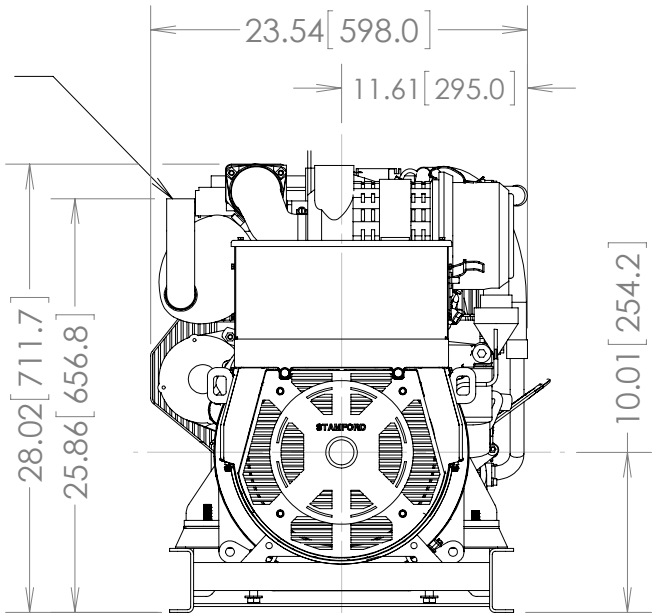
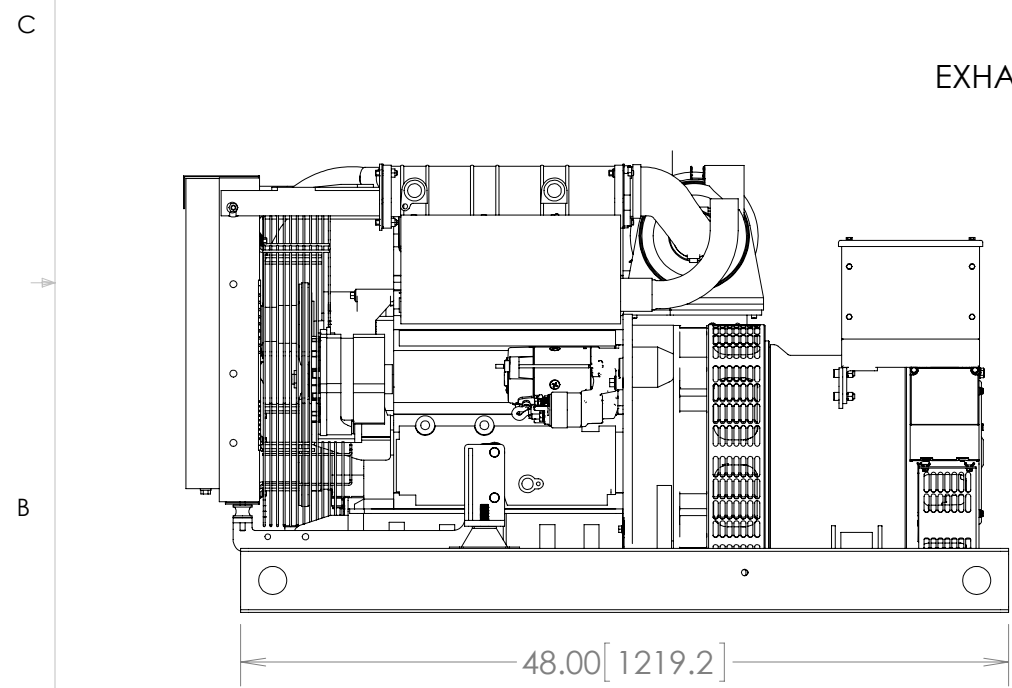
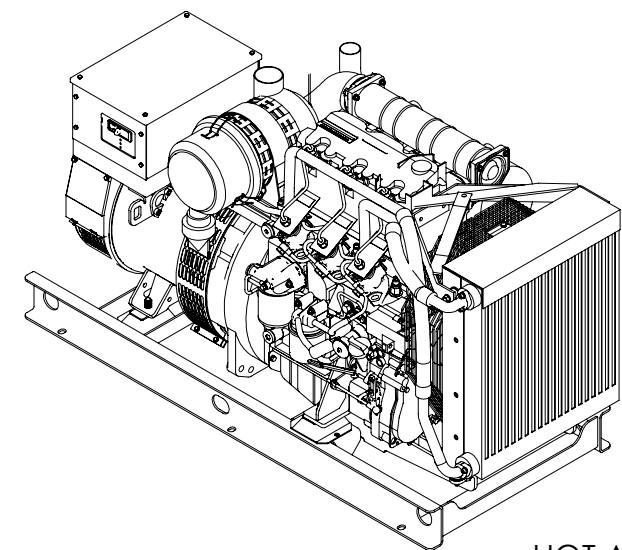

SERVICE SIDE

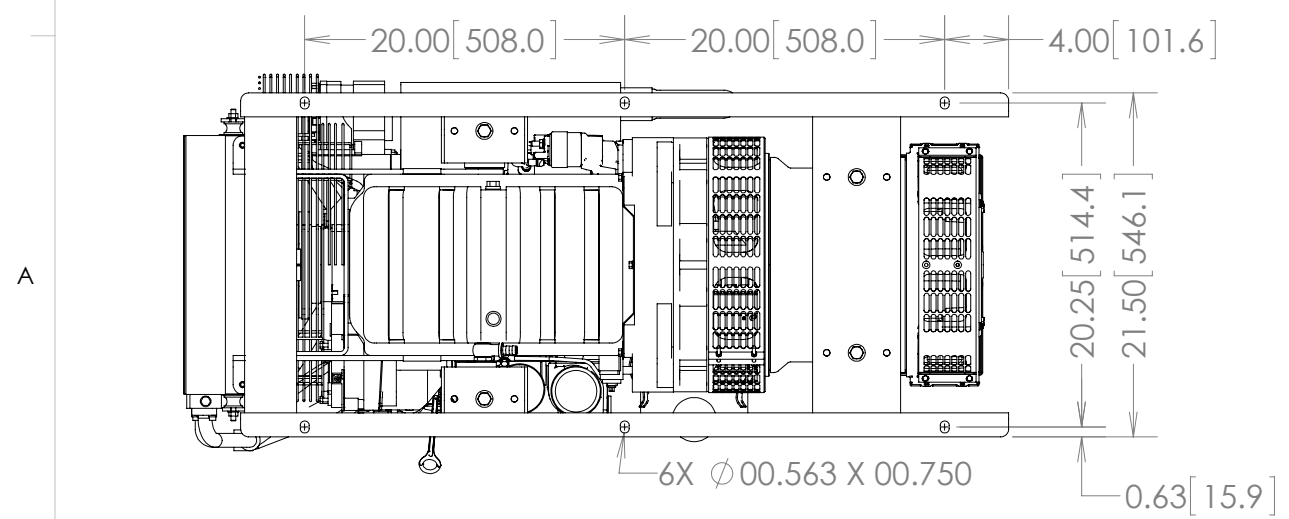

INFORMATION CONTAINED HEREIN
DEEMED RELIABLE BUT NOT GUARANTEED.

PROPRIETARY AND CONFIDENTIAL
THE INFORMATION CONTAINED IN THIS DRAWING IS THE SOLE PROPERTY OF STADCO/STAUFFER DIESEL INC. ANY REPRODUCTION IN PART OR AS A WHOLE WITHOUT THE WRITTEN PERMISSION OF STADCO/STAUFFER DIESEL INC. IS PROHIBITED.

TITLE: **CD20 GENSET LAYOUT**

THE FOLLOWING TOLERANCES APPLY UNLESS OTHERWISE SPECIFIED:

DIMENSIONS ARE IN INCHES [MM]
FRACTIONAL ± 1/32
ANGULAR: MACH ± 1° BEND ± 1°
ONE PLACE DECIMAL ± .060
TWO PLACE DECIMAL ± .030
THREE PLACE DECIMAL ± .010
DRILLED HOLES +.008 -.003
PUNCHED HOLES ± .016
MACHINED SURFACES ARE

STADCO STAUFFER DIESEL INC.
EPHRATA, PA., U.S.A. 17522

DRAWN BY: TJS	DATE: 11/08/2010	DWG. NO.: 12916
SCALE: 1:12	WEIGHT:	SHEET 1 OF 1

8 7 6 5 4 3 2 1